

TREBLE R FABRICATIONS

UNIT 42 – CROSSGATE ROAD – PARK FARM INDUSTRIAL ESTATE – REDDITCH – WORCS – B987SN

tel 01527 503 303 – fax 01527 503 325 – web www.treblefabrications.co.uk

CIRCULAR FLAP VALVES

UPVC FRAME AND RUBBER DOOR

The primary application of flap valves is for surface water drainage associated with rivers, estuaries and sea water outfalls to prevent reverse flow conditions. Flap valves can be utilised on final effluent outfalls for sewage treatment plant to prevent flood damage within the works.

The flap valves should be positioned on the outfall structure to avoid the build-up of debris around the invert area which could prevent the valve operating correctly. Sufficient ‘fall away’ should be provided between the invert of the flap valve and the base of the outfall structure.

Flap valve application on sea water outfalls should be given careful consideration due to turbulence of flow across the flap, particularly when severe wave action is involved, resulting in dislocation of the flap relative to the seats. Wherever possible the flap valve should be located in a shielded position to minimise the effects of severe wave action.

In many cases the end user preference is a light duty door with a fixed hinge to give minimal damage. The UPVC frame and flexible rubber door therefore satisfy this requirement, giving a minimal cracking head during operation. Subject to the clients needs and environmental conditions the selection of material can be mixed. The frame material available on this design is UPVC complete with a rubber 60 shore hardness door. All frame openings are reinforced to prevent the door imploding into the pipe and also to prevent illegal entry into the pipe (normally on sea fronts) by the general public.



CIRCULAR FLAP VALVES

Circular Flap Valves **UPVC Frame & Rubber Door**

Operating Duty

Application:	Prevents reverse flow
Type of Mounting:	Wall or PN16 Flanges
Type of Media:	Water and Sewage
Operating Head:	6 Metres on-seating

Options

Design Heads:	Higher head designs available
Size Range:	100mm to 600mm dia. nominal bore

Construction Materials

<u>ITEM</u>	<u>DESCRIPTION</u>	<u>MATERIAL</u>
1	Body	UPVC
2	Door	Rubber
3	Seal	Neoprene
4	Hinge Retainer	Stainless Steel
5	Fasteners	Stainless Steel, BS 6105, Gr A4

Circular Flap Valves UPVC Frame & Rubber Door

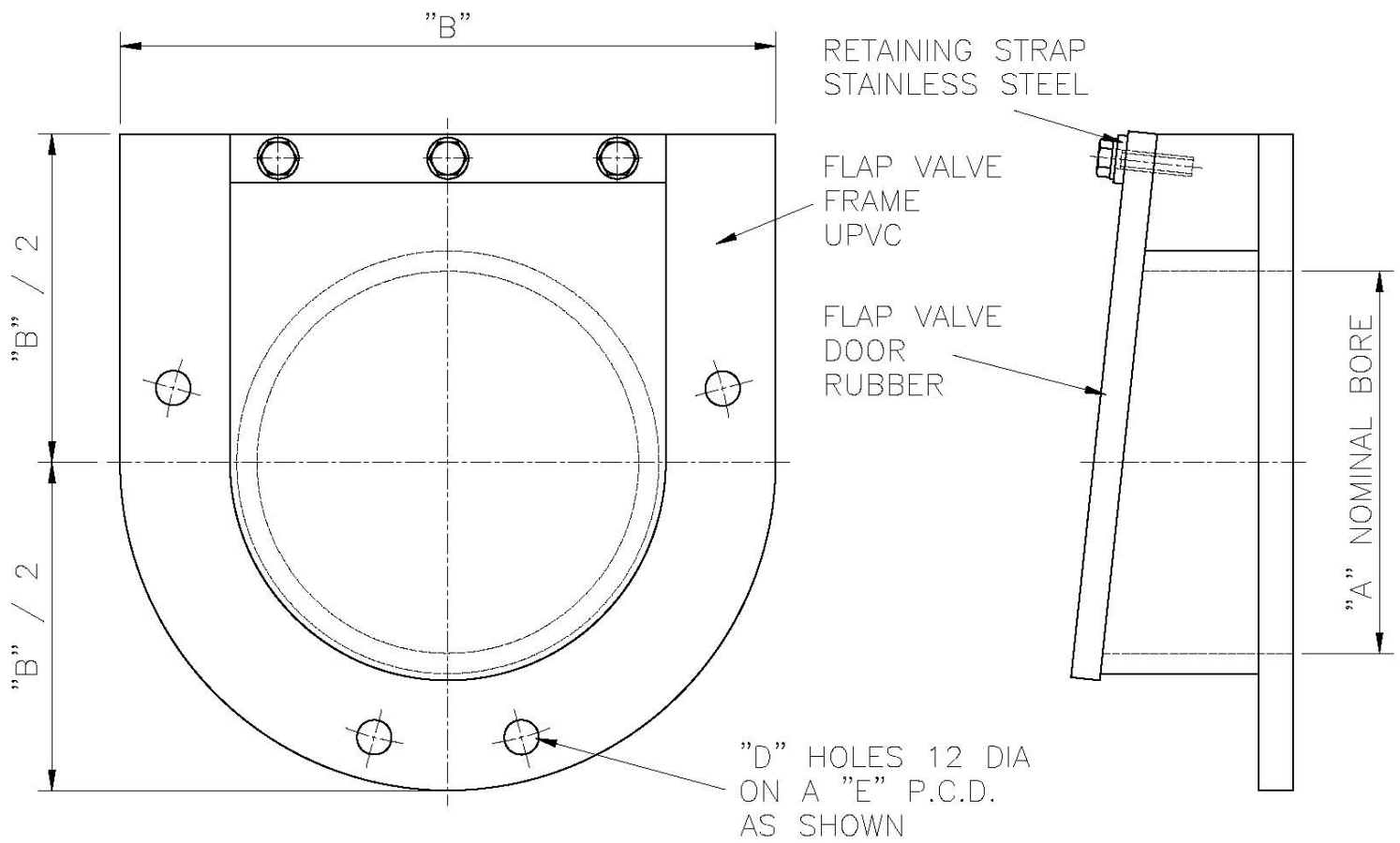

"A" BORE	"B"	"C"	"D"	"E"	DRILLING TYPE
80	200	106	4	160	1
100	220	108	4	180	1
150	285	114	4	240	1
200	340	120	4	295	2
225	368	123	4	324	1
250	405	126	6	355	3
300	460	130	6	410	3
350	520	134	8	470	4
400	580	139	8	525	4
450	640	146	8	585	5
500	715	152	8	650	5
600	840	163	8	770	5

Circular Flap Valves
UPVC Frame & Rubber Door
Drilling Details

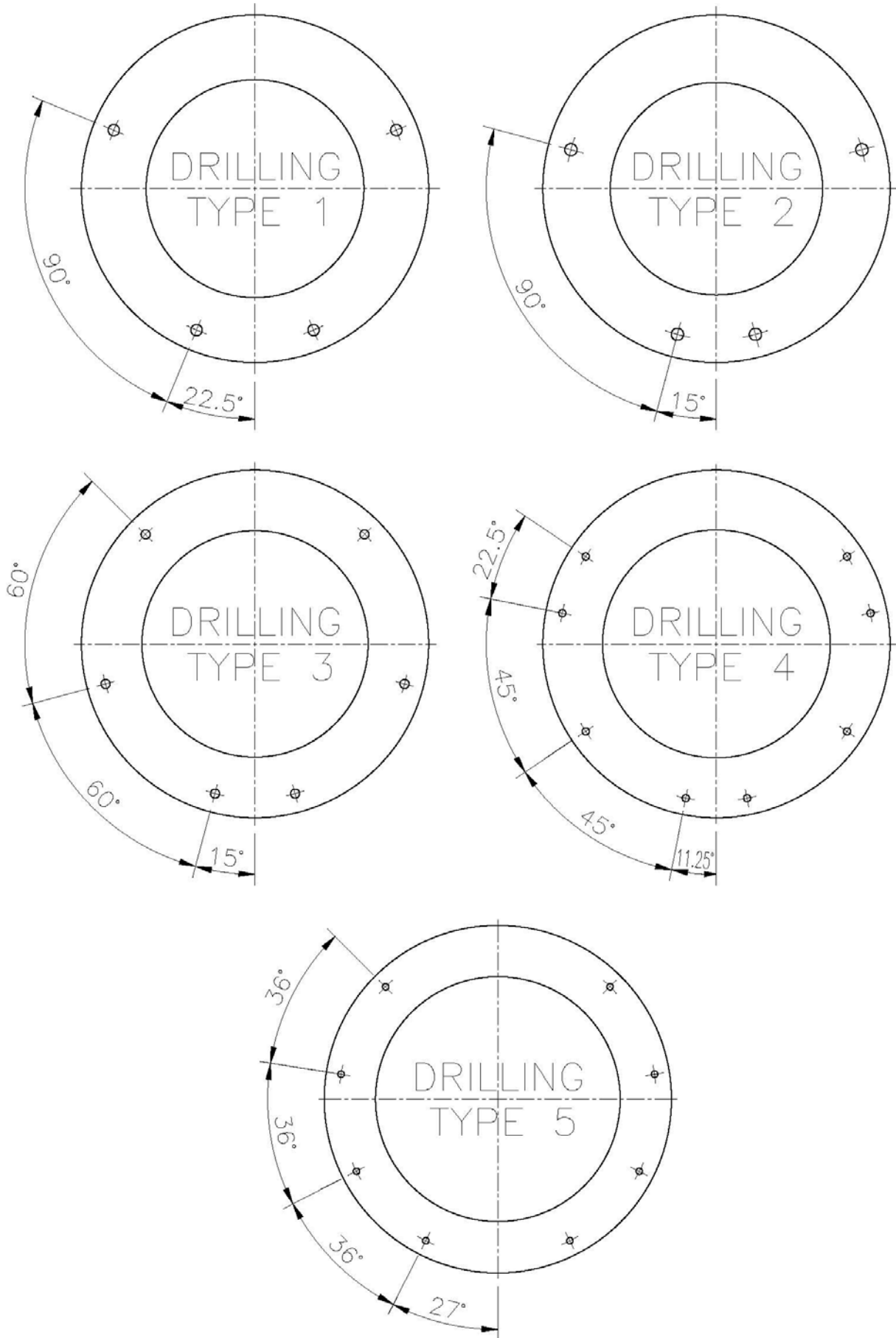

LOSS OF HEAD THROUGH FLAP GATES

Test conducted on flap gates show that the loss of head due to the flap riding on the water is very small compared with other losses in the hydraulic structure. Of course the entrance loss is usually considerably more critical than loss at the flap gate on the outlet end of conduit.

The hydraulic laboratory of the State University of Iowa conducted a series of test some years ago to determine the amount of head lost by water discharging through rectangular Flap Gates (Model 10C). The gates 16, 24 and 30 inches in diameter were supplied from commercial stock.

The following passage is excerpted from the report of Professor Floyd A. Nagler, associate professor of Mechanics and Hydraulics, who supervised the investigation.

Based on these experiments the following empirical formula was derived to express the loss in head through rectangular gates of varying sizes and with different velocities of flow.

L - Loss of head in feet

V - Velocity of flow through gate in feet per second

D - Diameter of outlet in feet

E - Base of natural logarithms.(2.7183)

$$L = \frac{4V^2}{G} \times E \left[\frac{-1.15V}{\oplus D} \right]$$

It may be concluded from these experiments that the rectangular gate in its hydraulic characteristics is all that the manufacturers have claimed for it. The small loss in head obtained through these gates demonstrates that their installation has but little effect on the discharged capacity of drainage outlets.

Medium and heavy duty flap gates have heavier flaps or covers than the gate model tested. As a result, head losses through these gates may be slightly more than those indicated by the test.

LOSS OF HEAD THROUGH FLAP GATES

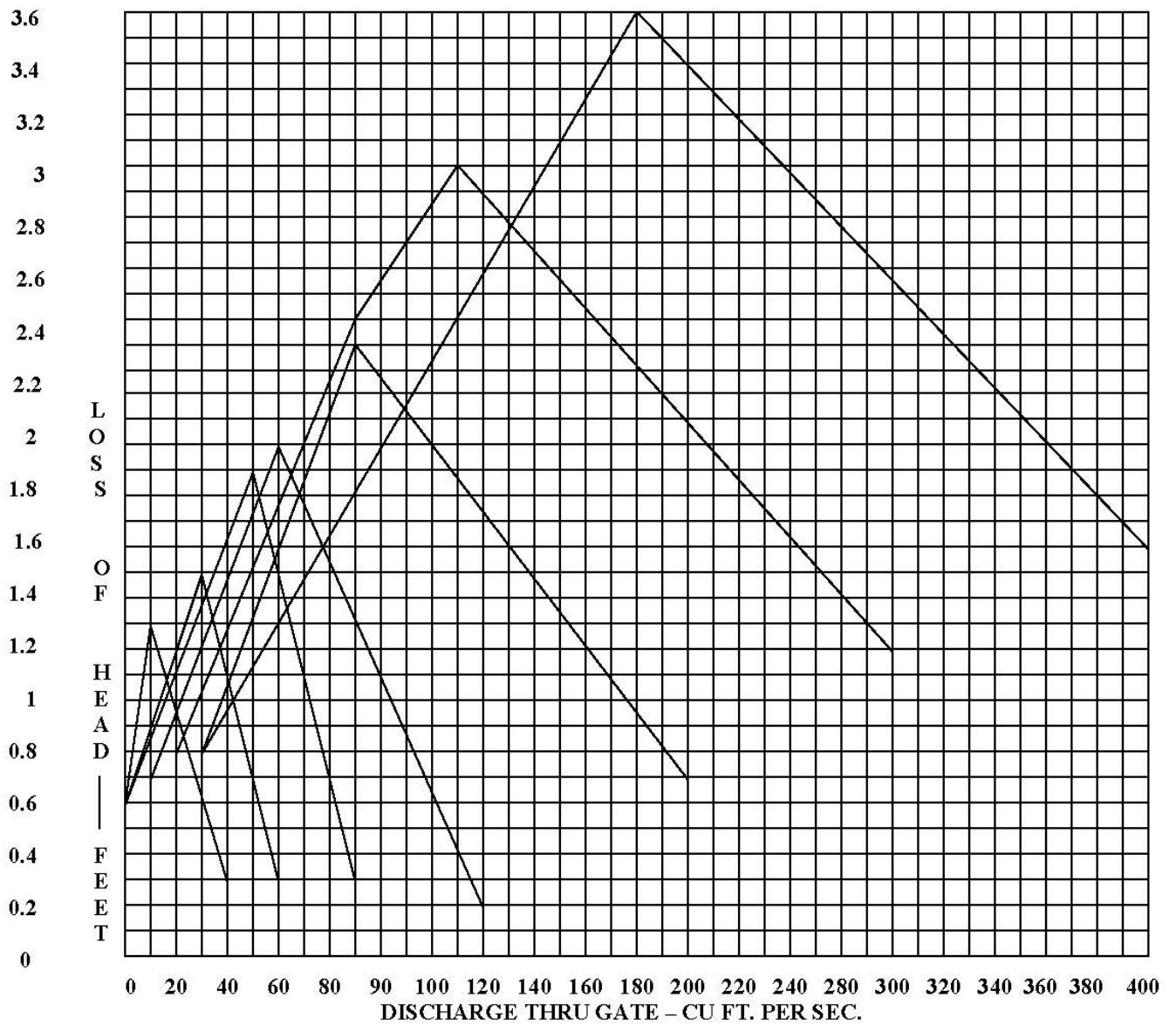
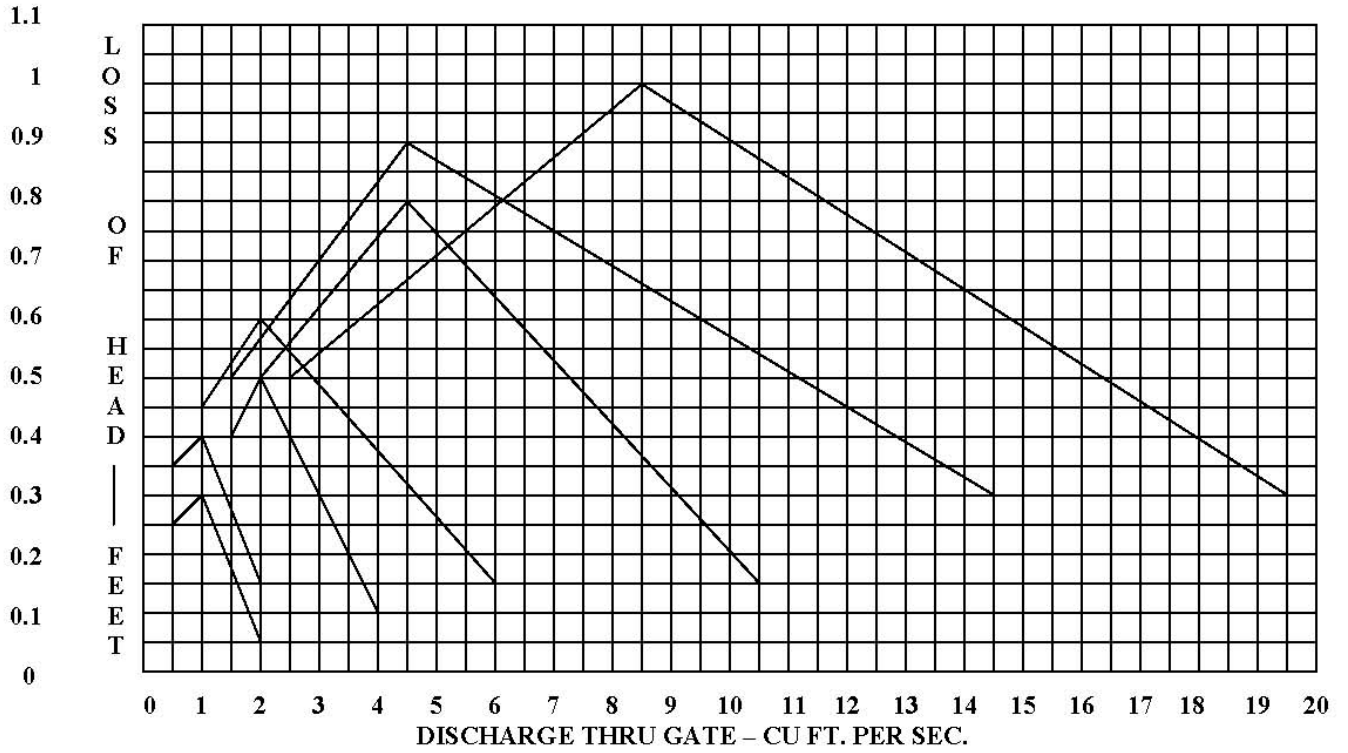

**Circular Flap Valves
UPVC Frame & Rubber Door
Head Loss Chart**

Diameter	Head Loss (mm)
100	(135)
150	(141)
200	(145)
225	(147)
250	(147)
300	(153)
350	(154)
400	(184)
450	(187)
500	(190)
600	(204)

Head loss based on velocity = 2.045 m/s and acceleration due to gravity = 9.81 m/s²